

**BAMBOO SOSPENSIONE**

0011.30  
0011.31

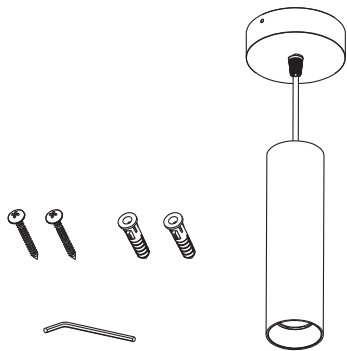

1

-disconnect the main voltage  
-scollegare la tensione di rete

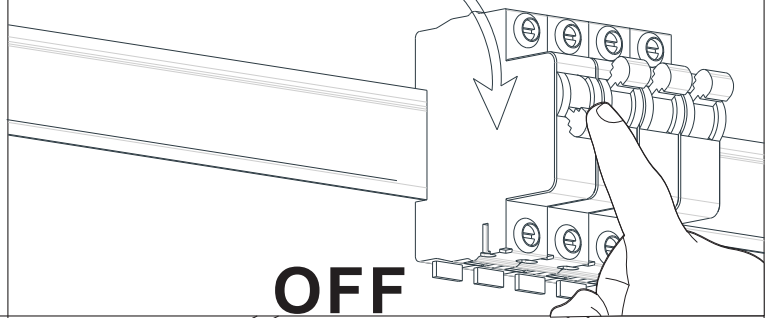

2

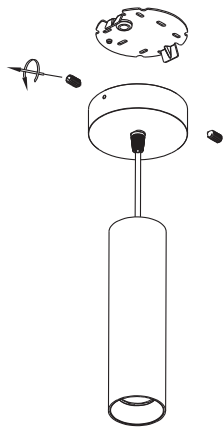

3

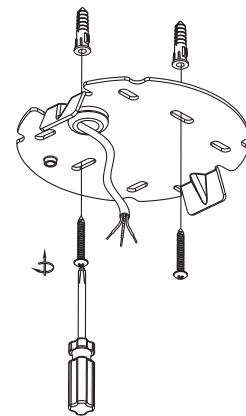

4

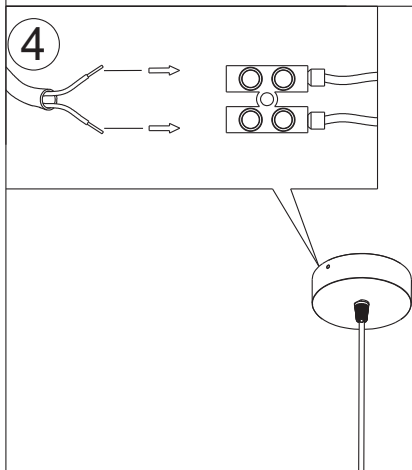

5

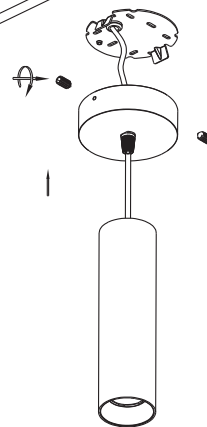

6

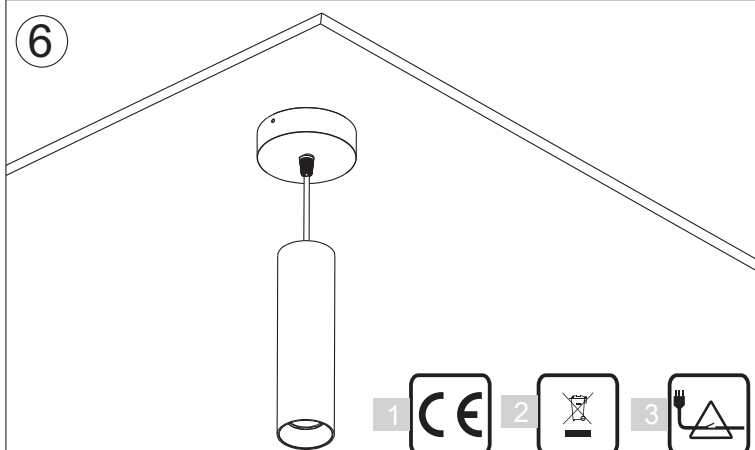

7

**ON**

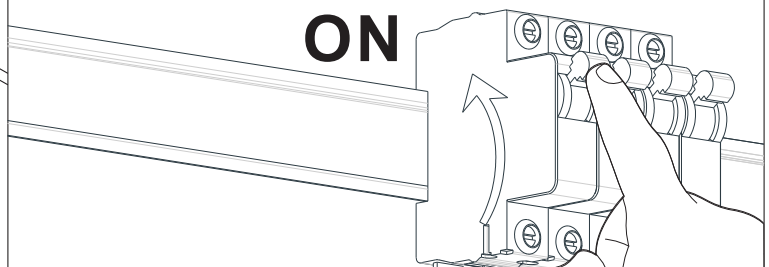

<b>Italian</b>	
1	Tutti i prodotti Vivida International S.r.l. sono realizzati in conformità alle normative e direttive europee.
2	In accordo alla normativa 2002/96/CE il prodotto alla fine della propria vita deve essere smaltito separatamente dai rifiuti urbani.
3	Se il cavo di questo apparecchio viene danneggiato, deve essere sostituito dal costruttore o dal suo servizio assistenza, o da personale qualificato equivalente, al fine di evitare pericoli
<b>English</b>	
1	All of Vivida International S.r.l. products are manufactured in compliance with the European regulations and directives.
2	In accordance with standard 2002/96/CE, at the end of its working life the product should be disposed of separately from urban waste.
3	If the cable of this appliance gets damaged, it must be replaced by the manufacturer or its after sale service, or by any equivalent and qualified staff, to avoid any danger.
<b>German</b>	
1	Alle Produkten bei Vivida international S.r.l. erfüllen mit Europäischen Vorschriften und Richtlinien.
2	In Übereinstimmung mit der richtlinie 2002/96/CE muss das gerät am ende seiner nutzungsdauer vom hausmüll getrennt entsorgt warden.
3	Sollte das Kabel beschaedigt worden sein, so darf dieses nur vom Herstelle/Elektrofachgeschaeft ersetzt werden.
<b>Spanish</b>	
1	Todos los productos Vivida International S.r.l. son realizados en conformidad con lasnormativas y directivas europeas.
2	De conformidad con la normativa 2002/96/ CE, al final de su vida útil el producto debe ser eliminado por separado de los residuos urbanos.
3	Si el cable de este producto ven estropeado, tiene que ser remplazado por parte del productor o por su servicio de asistencia, o por un equipo calificado, para evitar todos peligros.
<b>French</b>	
1	Tous les produits Vivida International S.r.l. sont réalisés en accord avec les règlements et directives européennes.
2	Selon la réglementation 2002/96/CE, le produit en fin de vie doit être éliminé séparément des déchets urbains.
3	Si le câble de cet appareil vient endommagé, il doit être remplacé par le producteur ou par son service après-vente, ou encore par du personnel également qualifié, afin d'éviter toutes formes de dangers.

### **WARNING:**

- La sorgente luminosa contenuta in questo apparecchio deve essere sostituita solo dal costruttore o dal suo servizio di assistenza o da personale altrettanto qualificato.

- The light source contained in this luminaire shall only be replaced by the manufacturer or his service agent or a similar qualified person.