

Rev	Design Change Note	Author	Date
A	Internal validation	ZP	2018-05-24
001	Approved by the client	ZP	2018-06-13

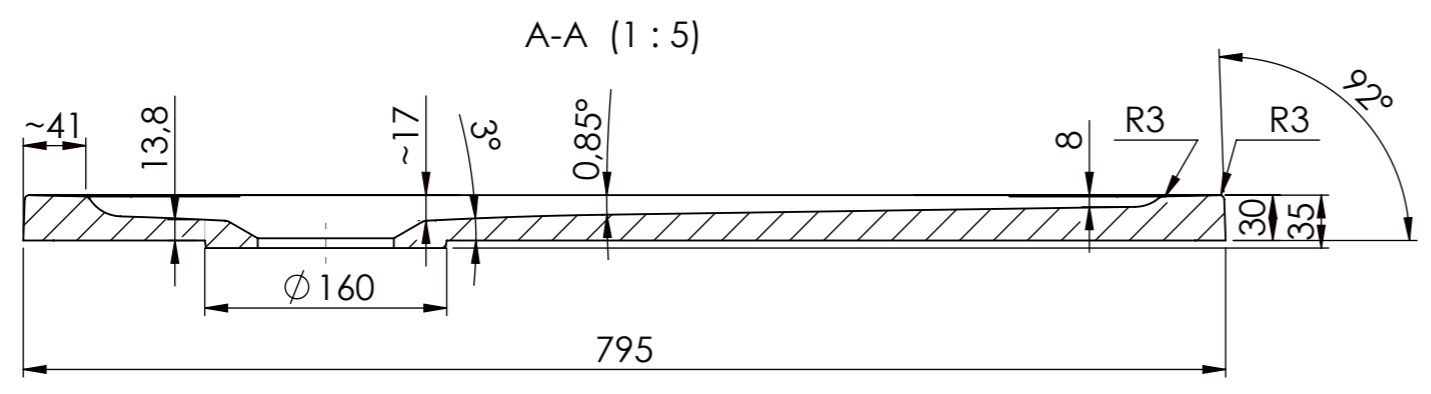

Antyślizp "MS053" in whole surface of slope/
Antyślizp "MS053" w całej powierzchni spływu

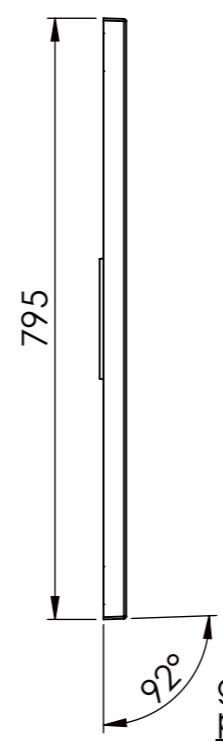
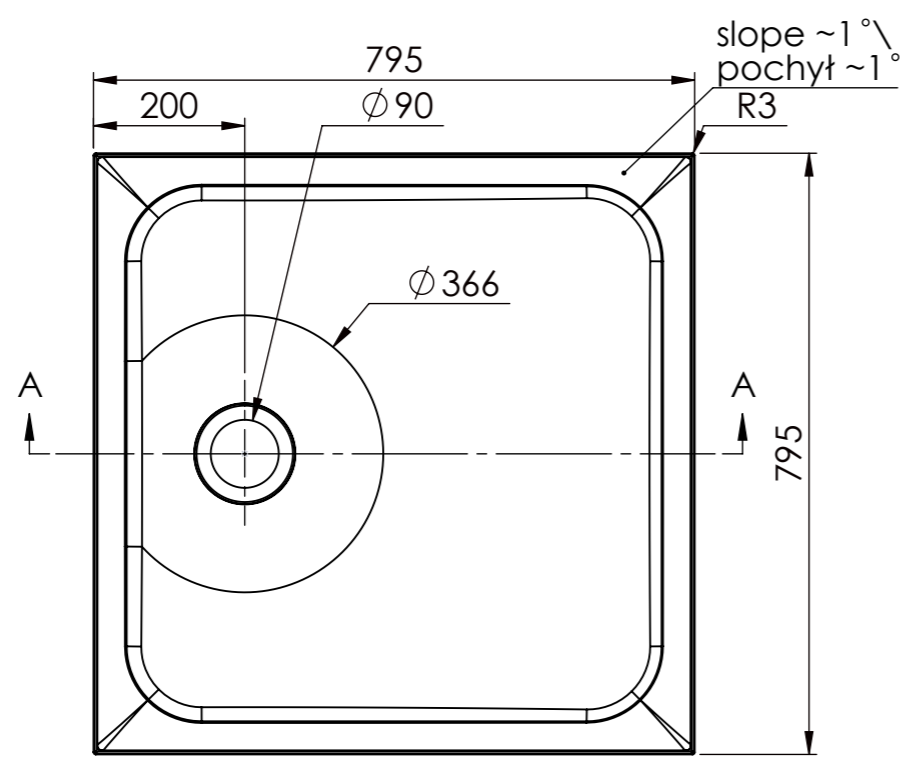
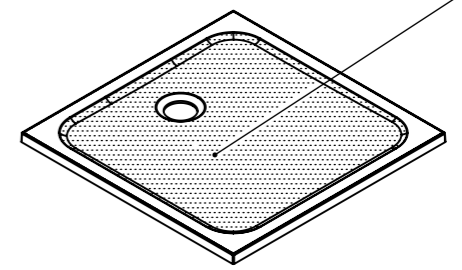

grinding area \ powierzchnia obrabiana
rough surface \ powierzchnia nieobrabiana

Bottom view - feet position/
Widok z dołu - rozstaw stópek

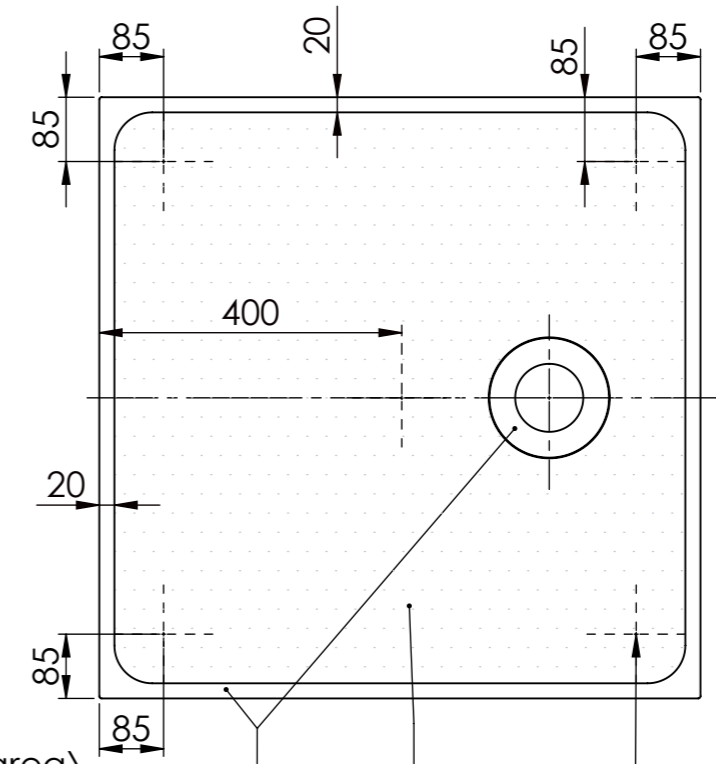

recommended feet position \
zalecana pozycja nóżek

This document must not be copied without our written permission, and the contents thereof must not be imparted to a third party nor be used for any unauthorized purpose. Contravention will be prosecuted.

Tolerance length/width	+5/0 mm	Drawn by	Zbigniew P	Created Date	2108-05-24	Checked by	Rafal B	Art. Name:	ST EASY 800X800 RECT		
Tolerance height	+2/-2 mm	Project status	Approved	Client	LEROY MERLIN	Art. No.:	6073380820xx	Mould No.:	F7338082		
Tolerance plane bending	<1200 mm +2/-2 mm ≥1200 mm +3/-3 mm							Customer ID:	3127		
Tolerance thickness	+2/-2 mm	Material volume [mm³]	13399921	Overflow	No	Tap hole	0	Main dimensions L x W / H [mm]	795 x 795 / 35		
Tolerance grinding	+2/0 mm	Surface area [mm²]	1351073	Sheet Size	A3	Scale	1:10	Current revision	001	Drain	Regular
Tolerance feet location	+7/-7 mm									Sheet	1 \ 1
Tolerance holes location	+2/-2 mm										
Tolerance holes diameter	+1/-1 mm										