

| Rev | Design Change Note | Author | Date |
|-----|------------------------|--------|------------|
| A | Internal validation | ZP | 2018-05-24 |
| 001 | Approved by the client | ZP | 2018-06-13 |

A-A (1:5)

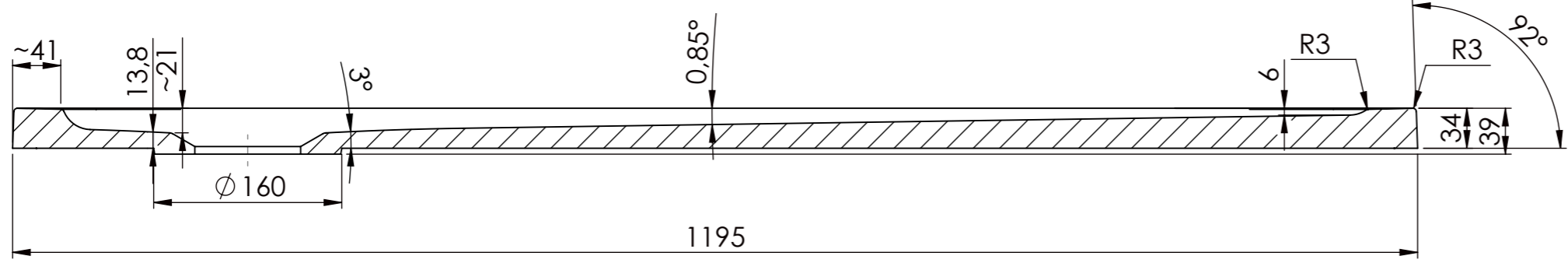

Antyślizp "MS053" in whole surface of slope/
Antyślizp "MS053" w całej powierzchni spływu

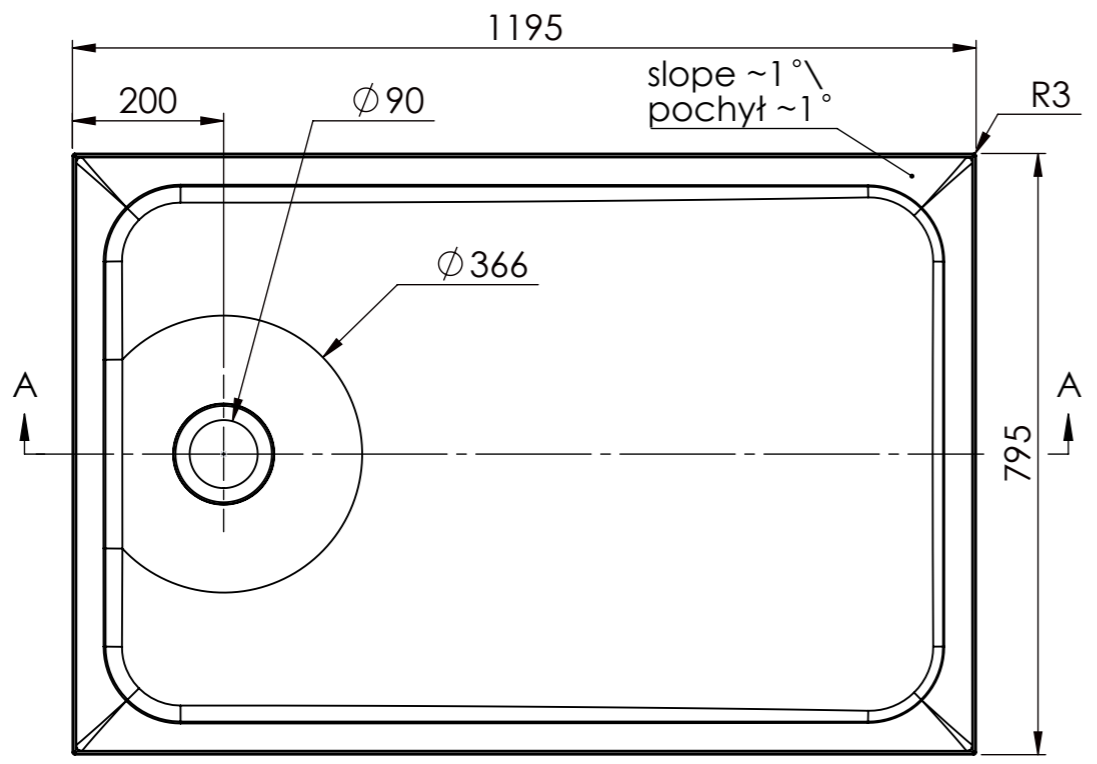
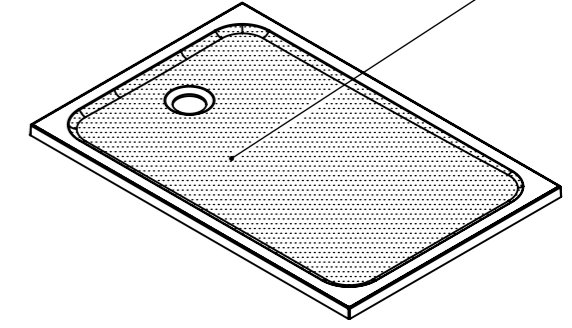

Bottom view - feet position/
Widok z dołu - rozstaw stópek

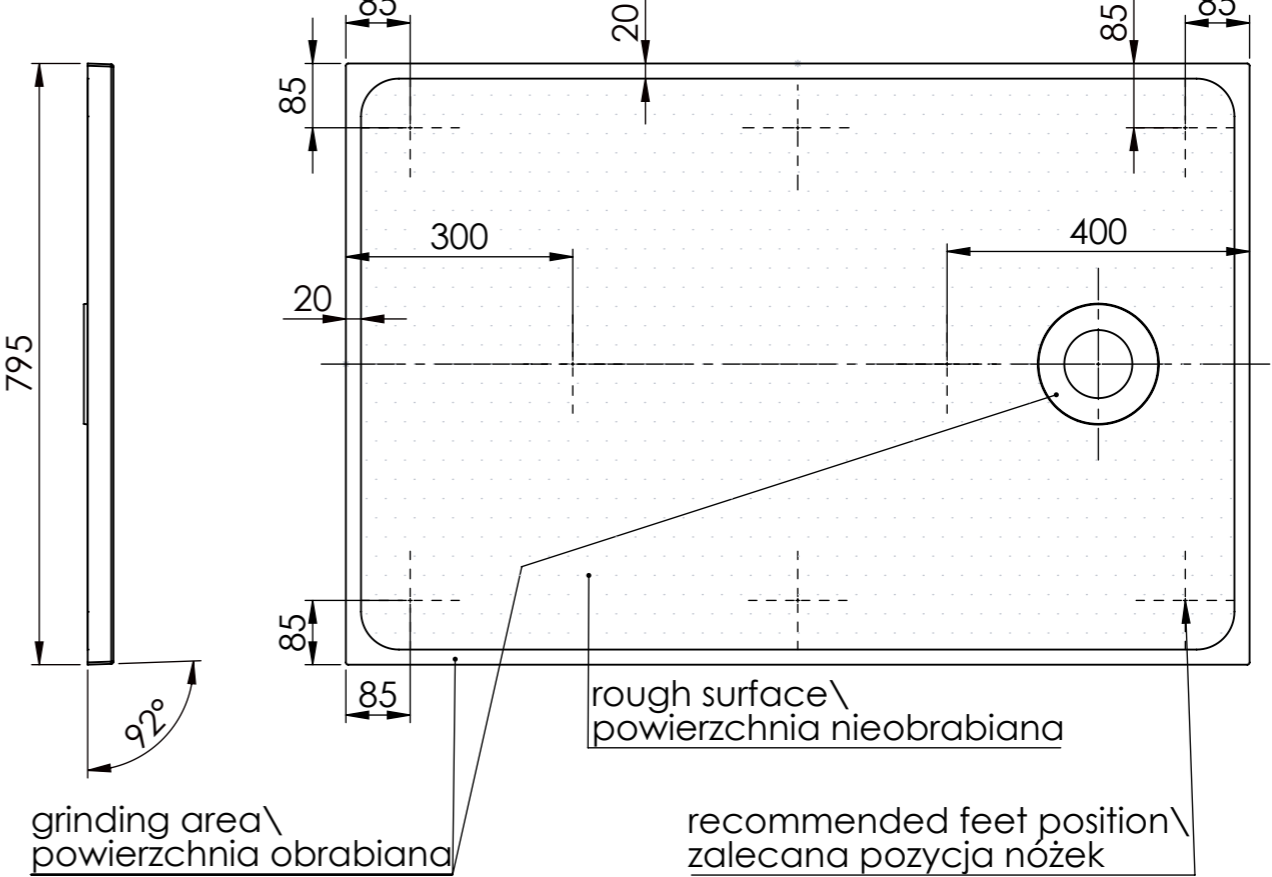

| | | | | | | | | | | |
|--------------------------|---|----------------|------------|--------------------|--------------|--------------------------------|-----------------|------------|-----------------------|---------|
| Tolerance length/width | +5/0 mm | Drawn by | Zbigniew P | Created Date | 2018-05-24 | Checked by | Rafal B | Art. Name: | ST EASY 1200X800 RECT | |
| Tolerance height | +2/-2 mm | Project status | Approved | Client | LEROY MERLIN | Art. No.: | 6073381230xx | Mould No.: | F7338123 | |
| Tolerance plane bending | <1200 mm: +2/-2 mm >=1200 mm: +3/-3 mm | | | Customer ID: | 3127 | Material volume [mm³] | 22461507 | Overflow | No | |
| Tolerance thickness | +2/-2 mm | | | Surface area [mm²] | 2029701 | Sheet Size | A3 | Scale | 1:10 | |
| Tolerance grinding | +2/0 mm | | | | | Main dimensions L x W / H [mm] | 1195 x 795 / 39 | | Drain | Regular |
| Tolerance feet location | +7/-7 mm | | | | | Current revision | 001 | Sheet | 1 \ 1 | |
| Tolerance holes location | +2/-2 mm | | | | | | | | | |
| Tolerance holes diameter | +1/-1 mm | | | | | | | | | |



This document must not be copied without our written permission, and the contents thereof must not be imparted to a third party nor be used for any unauthorized purpose. Contravention will be prosecuted.