

Rev	Design Change Note	Author	Date
A	Internal validation	RB	2018-06-12
001	First issue - proposal	RB	2018-06-15
002	Approved by client	RB	2018-06-25

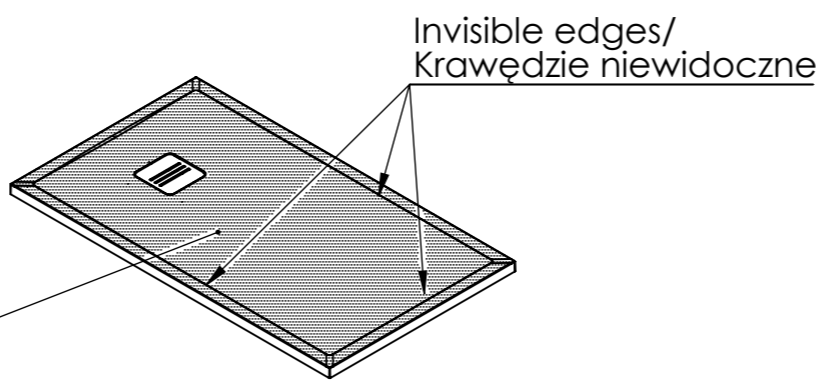

Bottom view - feet position/
Widok z dołu - rozstaw stópek

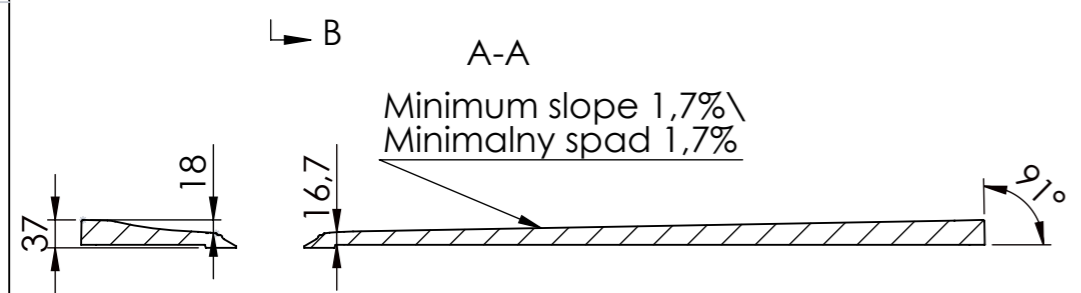
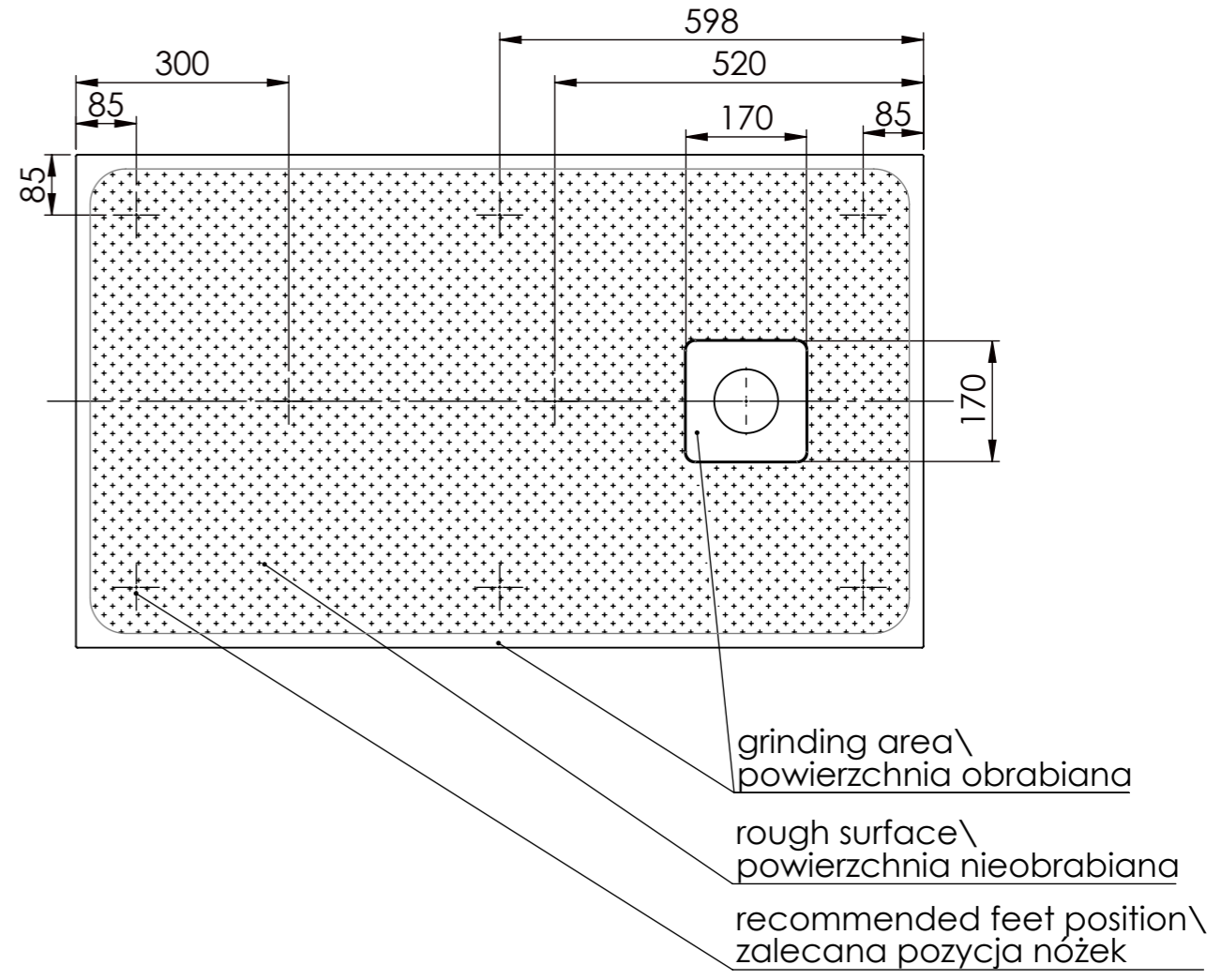
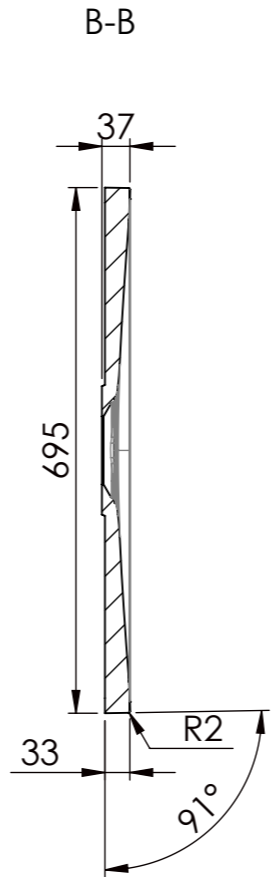
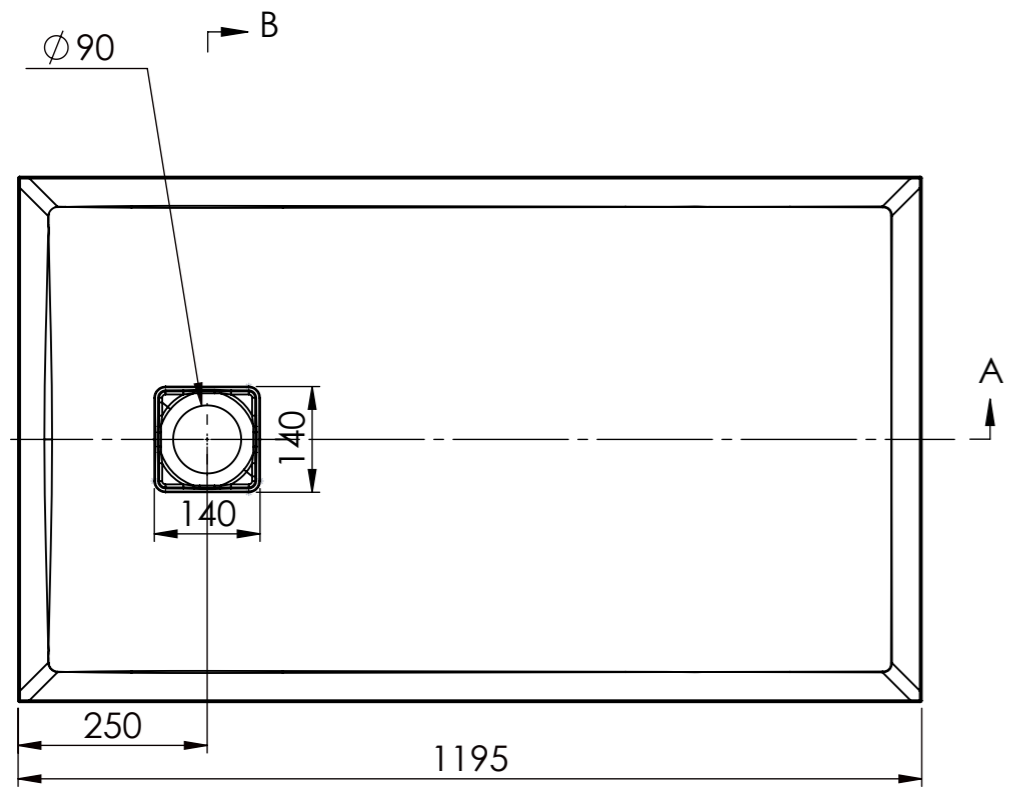

Notes/Uwagi:

1. Steel plate - see drawing 103300000055/Metalowa przykrywka - patrz rysunek 103300000055

Tolerance length/width	+5/0 mm	Drawn by	Created Date	Checked by	Art. Name: REMIX 1 1200x700			
Tolerance height	+2/-2 mm	Rafal B	2018-06-12	Zbigniew P	Art. No: 6073411230xx			
Tolerance plane bending	<1200 mm +2/-2 mm ≥1200 mm +3/-3 mm	Project status	Client		Mould No: FZ341123			
		Approved	LEROY MERLIN		Customer ID: 3127			
Tolerance thickness	+2/-2 mm			Material volume [mm ³]	Overflow	Taphole	Main dimensions L x W / H [mm]	Drain
Tolerance grinding	+2/0 mm			22578517	No	0	1200 x 700 / 37	Cover
Tolerance feet location	+7/-7 mm	Surface area [mm ²]	Sheet Size	Scale			Current revision	
Tolerance holes location	+2/-2 mm	1773247	A3	1:10			002	
Tolerance holes diameter	+1/-1 mm							

This document must not be copied without our written permission, and the contents thereof must not be imparted to a third party nor be used for any unauthorized purpose. Contravention will be prosecuted.